

| REVISIONS | | | | | |
|-----------|------|-----|---|-----------|---------|
| ECO | ZONE | REV | DESCRIPTION | DATE | BY |
| 205432 | 5 | A | SLIP RING CORD 22 - ADDED WIRE 1533 TO ENGINE CONNECTOR AND WIRE 1533 TO CAB 25 AND WIRE 2159 TO CAB 5. | 11-MAY-10 | BER JRL |
| 205771 | 5 | C | DELETED WIRE 1533 | 04-OCT-10 | MEM JRL |

PROVIDE LABELING INFORMATION FOR THE SHOWN AND THE SHOWN WIRE CONNECTIONS. THE SHOWN AND THE SHOWN WIRE CONNECTIONS MUST BE IDENTIFIED BY THE SHOWN AND THE SHOWN WIRE CONNECTIONS. THE SHOWN AND THE SHOWN WIRE CONNECTIONS MUST BE IDENTIFIED BY THE SHOWN AND THE SHOWN WIRE CONNECTIONS. THE SHOWN AND THE SHOWN WIRE CONNECTIONS MUST BE IDENTIFIED BY THE SHOWN AND THE SHOWN WIRE CONNECTIONS.

| | | | | | |
|---|--|---------------------------|---------------------------|---------------------------|---------------------------|
| PRIVATE LABELING INFORMATION TO BE PROVIDED TO THE CUSTOMER. THE CUSTOMER MUST BE PROVIDED WITH THE SHOWN AND THE SHOWN WIRE CONNECTIONS. THE SHOWN AND THE SHOWN WIRE CONNECTIONS MUST BE IDENTIFIED BY THE SHOWN AND THE SHOWN WIRE CONNECTIONS. THE SHOWN AND THE SHOWN WIRE CONNECTIONS MUST BE IDENTIFIED BY THE SHOWN AND THE SHOWN WIRE CONNECTIONS. | APPROVALS DATE APPROVALS DATE | DATE APPROVALS DATE | DATE APPROVALS DATE | DATE APPROVALS DATE | DATE APPROVALS DATE |
| APPROVALS DATE | APPROVALS DATE | APPROVALS DATE | APPROVALS DATE | APPROVALS DATE | APPROVALS DATE |

GROVE

ELECTRICAL SCHEMATIC

RT9150E4

DATE: 08/02/07

REV: J

RT9150E CONTROL SYSTEM TWIN-LOCK

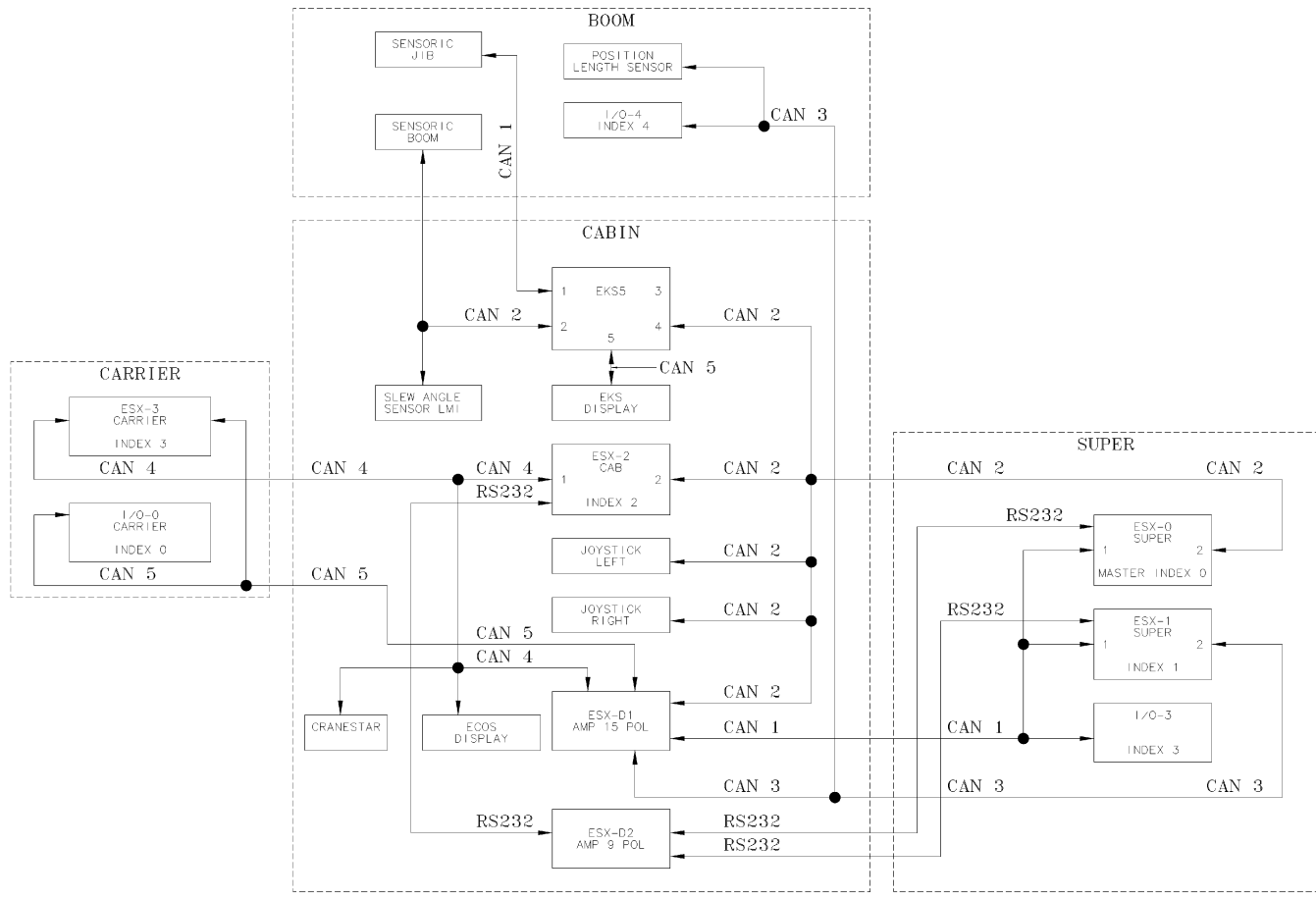

THE INFORMATION AND SPECIFICATIONS INFORMATION THIS DRAWING AND THE RELATED WORK CONTAINED HEREIN IS THE PROPERTY OF GROVE CRANES AND CONSTRUCTION EQUIPMENT COMPANY. IT IS TO BE USED ONLY FOR THE PROJECT AND SITE SPECIFICALLY IDENTIFIED ON THIS DRAWING. IT IS NOT TO BE REPRODUCED, COPIED, OR TRANSMITTED IN ANY FORM OR BY ANY MEANS, ELECTRONIC OR MECHANICAL, INCLUDING PHOTOCOPYING, RECORDING, OR BY ANY INFORMATION STORAGE AND RETRIEVAL SYSTEM. GROVE CRANES AND CONSTRUCTION EQUIPMENT COMPANY SHALL BE HELD HARMLESS FROM ANY AND ALL DAMAGES, LOSSES, AND EXPENSES, INCLUDING ATTORNEY'S FEES, ARISING OUT OF OR RESULTING FROM THE USE OF THIS DRAWING. APPROVED BY: [Signature] DATE: [Date]

| | | | | | | | | | | | |
|---|------------------------------|----------------------------------|---|---|---|------------------------|--|-----------------------------|--|-----------------------|----------|
| PRIVATE LABELING REQUIREMENT TO COMPANY, CO. SPECIFICATION REQUIREMENTS ENTERED IN 425500-05-030 | ADDITIONAL APPROVALS DATE | DATE 3RD ANGLE PROJECTION | UNLESS SPEC. NUMBER USE DIM FOR ALTERNATES | DO NOT SCALE DRAWING IN DIM. OCC. PLACES MM DIM. N. P.A. DIMENSIONS TO 1:1000 4.00" ± 0.005" PLACE DEC. TO 0.000 1.016" ± 0.005" PLACE DEC. TO 0.000 ±2° ANGULAR DIM. 12" N/A TO MATERIAL THICKNESS | TO DRAWER UNLESS OTHERWISE SPECIFIED | CONTRACT NO. 205230 | APPROVALS DATE DESIGNED CHECKED APPROVED A. CALTA | DATE 04/20/2024 12:31 | GROVE ELECTRICAL SCHEMATIC RT9150E4 | SHEET NO. 80025078 | REV J |
|---|------------------------------|----------------------------------|---|---|---|------------------------|--|-----------------------------|--|-----------------------|----------|

80025078 107

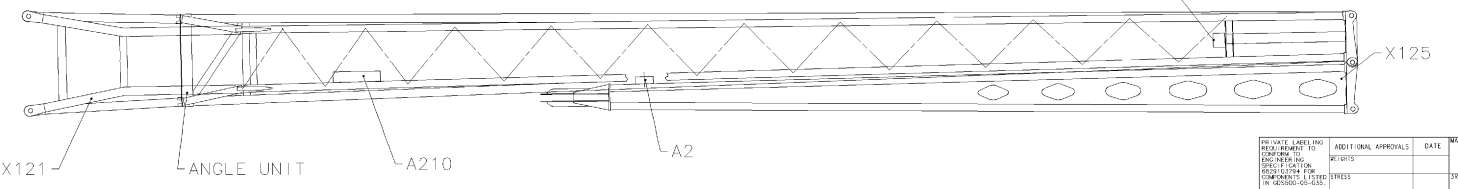
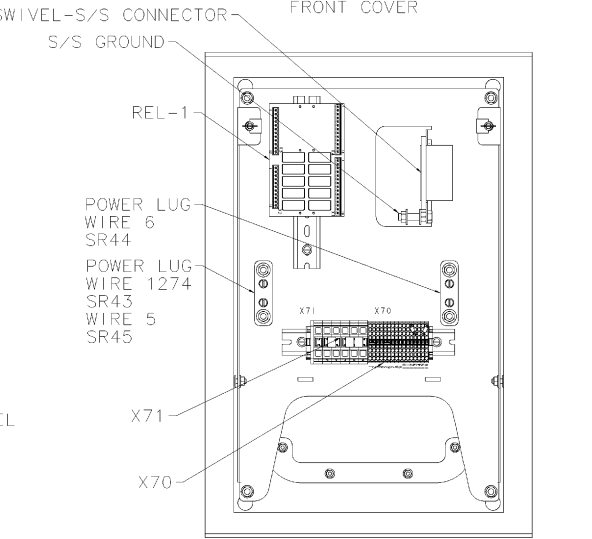
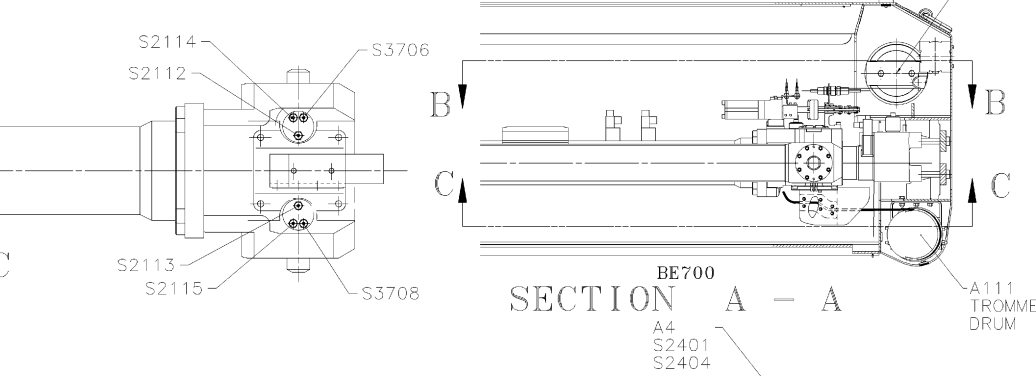
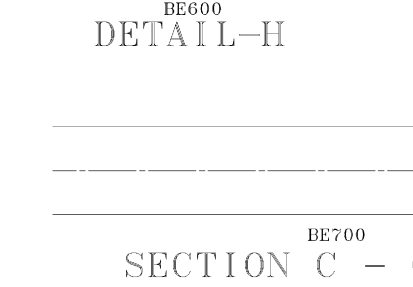
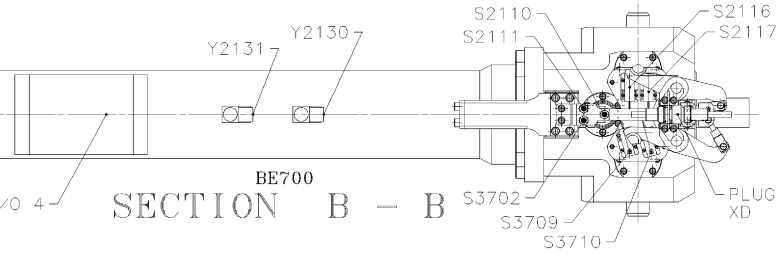
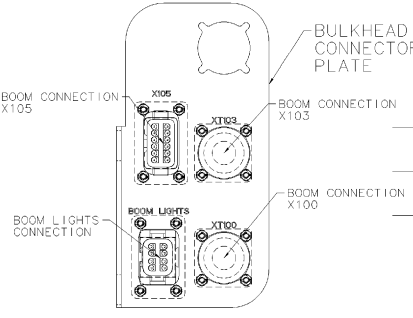
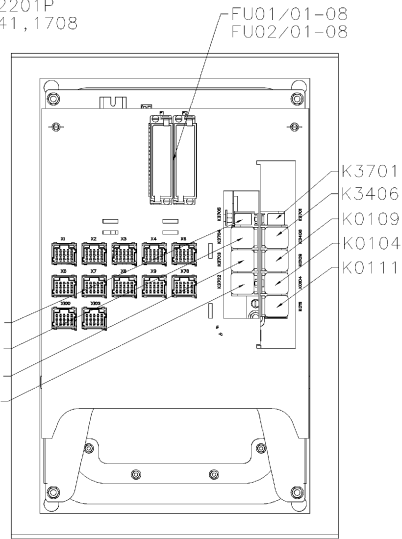
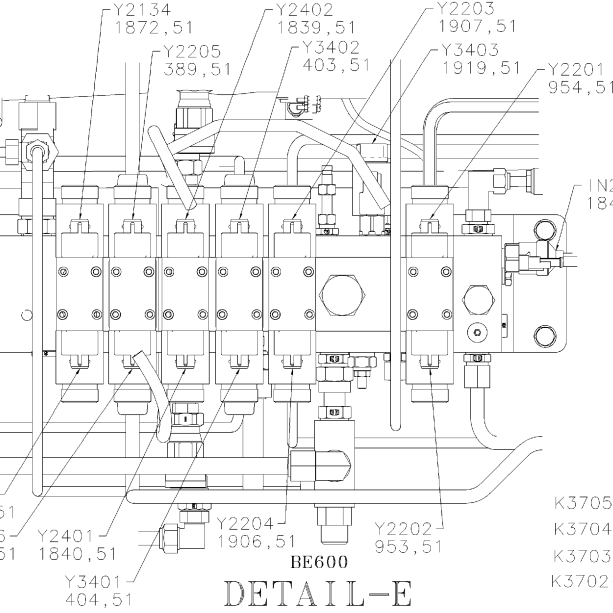
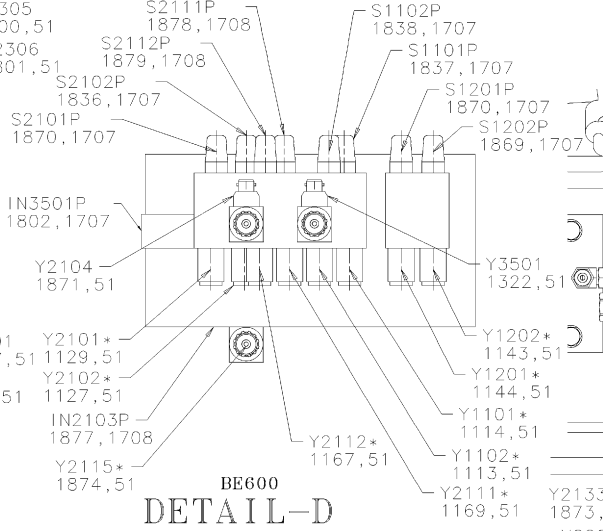
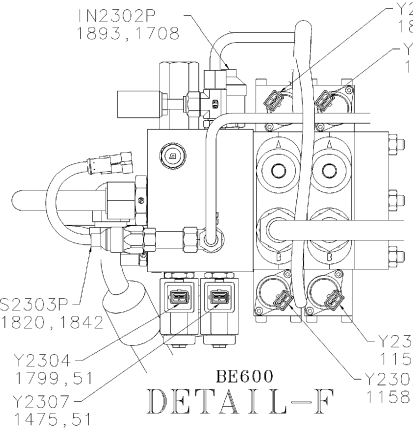

REVISIONS AND MODIFICATIONS TO THIS DRAWING ARE TO BE MADE BY THE DESIGNER OR HIS AUTHORIZED REPRESENTATIVE. THE USER SHALL BE RESPONSIBLE FOR VERIFYING THE ACCURACY OF THE INFORMATION PROVIDED IN THIS DRAWING. THE USER SHALL BE RESPONSIBLE FOR VERIFYING THE ACCURACY OF THE INFORMATION PROVIDED IN THIS DRAWING. THE USER SHALL BE RESPONSIBLE FOR VERIFYING THE ACCURACY OF THE INFORMATION PROVIDED IN THIS DRAWING.

| | | | | | |
|--|---|---|---|---|----------------------------|
| PRIVATE LABELING REQUIRED TO BE OBTAINED FROM GROVE, INC. SPECIFIC CATION INFORMATION FOR COMPONENTS FROM GROVE, INC. IS REQUIRED. | ADDITIONAL APPROVALS DATE | DATE 3RD ANGLE PROJECTION | TITLE SPEC. NUMBER (SEE ROW FOR ALTERNATE VIEWS) | DO NOT SCALE DRAWING TO DIMENSIONS UNLESS OTHERWISE SPECIFIED | CONTRACT NO. EC5 205230 |
| MATCH WELDING WELD SYMBOLS IF IN DOUBT ASK, REMOVE ALL RIBS AND SHARP EDGES. | APPROVALS DATE APPROVED DATE APPROVED DATE | IN DIM. ECC. PLACES MM DIM. IN DIM. UNLESS OTHERWISE SPECIFIED 1/8" DIA. 3 PLAGE DEC. 1/16" DIA. 1/4" DIA. 3 PLAGE DEC. 1/8" DIA. 1/2" DIA. 3 PLAGE DEC. 1/4" DIA. 3/4" DIA. 3 PLAGE DEC. 1/2" DIA. 1" DIA. 3 PLAGE DEC. 3/4" DIA. 1 1/2" DIA. 3 PLAGE DEC. 1" DIA. 2" DIA. 3 PLAGE DEC. 1 1/2" DIA. 3" DIA. 3 PLAGE DEC. 2" DIA. 4" DIA. 3 PLAGE DEC. 2 1/2" DIA. 6" DIA. 3 PLAGE DEC. 3" DIA. 8" DIA. 3 PLAGE DEC. 3 1/2" DIA. 10" DIA. 3 PLAGE DEC. 4" DIA. 12" DIA. 3 PLAGE DEC. 4 1/2" DIA. 14" DIA. 3 PLAGE DEC. 4 3/4" DIA. 16" DIA. 3 PLAGE DEC. 5" DIA. 18" DIA. 3 PLAGE DEC. 5 1/2" DIA. 20" DIA. 3 PLAGE DEC. 5 3/4" DIA. 24" DIA. 3 PLAGE DEC. 6" DIA. 30" DIA. 3 PLAGE DEC. 7" DIA. 36" DIA. 3 PLAGE DEC. 8" DIA. 42" DIA. 3 PLAGE DEC. 9" DIA. 48" DIA. 3 PLAGE DEC. 10" DIA. 54" DIA. 3 PLAGE DEC. 11" DIA. 60" DIA. 3 PLAGE DEC. 12" DIA. 72" DIA. 3 PLAGE DEC. 14" DIA. 84" DIA. 3 PLAGE DEC. 16" DIA. 96" DIA. 3 PLAGE DEC. 18" DIA. 108" DIA. 3 PLAGE DEC. 20" DIA. 120" DIA. 3 PLAGE DEC. 22" DIA. 144" DIA. 3 PLAGE DEC. 24" DIA. 168" DIA. 3 PLAGE DEC. 26" DIA. 192" DIA. 3 PLAGE DEC. 28" DIA. 216" DIA. 3 PLAGE DEC. 30" DIA. 240" DIA. 3 PLAGE DEC. 32" DIA. 264" DIA. 3 PLAGE DEC. 34" DIA. 288" DIA. 3 PLAGE DEC. 36" DIA. 312" DIA. 3 PLAGE DEC. 38" DIA. 336" DIA. 3 PLAGE DEC. 40" DIA. 360" DIA. 3 PLAGE DEC. 42" DIA. 384" DIA. 3 PLAGE DEC. 44" DIA. 408" DIA. 3 PLAGE DEC. 46" DIA. 432" DIA. 3 PLAGE DEC. 48" DIA. 456" DIA. 3 PLAGE DEC. 50" DIA. 480" DIA. 3 PLAGE DEC. 52" DIA. 504" DIA. 3 PLAGE DEC. 54" DIA. 528" DIA. 3 PLAGE DEC. 56" DIA. 552" DIA. 3 PLAGE DEC. 58" DIA. 576" DIA. 3 PLAGE DEC. 60" DIA. 600" DIA. 3 PLAGE DEC. 62" DIA. 624" DIA. 3 PLAGE DEC. 64" DIA. 648" DIA. 3 PLAGE DEC. 66" DIA. 672" DIA. 3 PLAGE DEC. 68" DIA. 696" DIA. 3 PLAGE DEC. 70" DIA. 720" DIA. 3 PLAGE DEC. 72" DIA. 744" DIA. 3 PLAGE DEC. 74" DIA. 768" DIA. 3 PLAGE DEC. 76" DIA. 792" DIA. 3 PLAGE DEC. 78" DIA. 816" DIA. 3 PLAGE DEC. 80" DIA. 840" DIA. 3 PLAGE DEC. 82" DIA. 864" DIA. 3 PLAGE DEC. 84" DIA. 888" DIA. 3 PLAGE DEC. 86" DIA. 912" DIA. 3 PLAGE DEC. 88" DIA. 936" DIA. 3 PLAGE DEC. 90" DIA. 960" DIA. 3 PLAGE DEC. 92" DIA. 984" DIA. 3 PLAGE DEC. 94" DIA. 1008" DIA. 3 PLAGE DEC. 96" DIA. 1032" DIA. 3 PLAGE DEC. 98" DIA. 1056" DIA. 3 PLAGE DEC. 100" DIA. 1080" DIA. 3 PLAGE DEC. 102" DIA. 1104" DIA. 3 PLAGE DEC. 104" DIA. 1128" DIA. 3 PLAGE DEC. 106" DIA. 1152" DIA. 3 PLAGE DEC. 108" DIA. 1176" DIA. 3 PLAGE DEC. 110" DIA. 1200" DIA. 3 PLAGE DEC. 112" DIA. 1224" DIA. 3 PLAGE DEC. 114" DIA. 1248" DIA. 3 PLAGE DEC. 116" DIA. 1272" DIA. 3 PLAGE DEC. 118" DIA. 1296" DIA. 3 PLAGE DEC. 120" DIA. 1320" DIA. 3 PLAGE DEC. 122" DIA. 1344" DIA. 3 PLAGE DEC. 124" DIA. 1368" DIA. 3 PLAGE DEC. 126" DIA. 1392" DIA. 3 PLAGE DEC. 128" DIA. 1416" DIA. 3 PLAGE DEC. 130" DIA. 1440" DIA. 3 PLAGE DEC. 132" DIA. 1464" DIA. 3 PLAGE DEC. 134" DIA. 1488" DIA. 3 PLAGE DEC. 136" DIA. 1512" DIA. 3 PLAGE DEC. 138" DIA. 1536" DIA. 3 PLAGE DEC. 140" DIA. 1560" DIA. 3 PLAGE DEC. 142" DIA. 1584" DIA. 3 PLAGE DEC. 144" DIA. 1608" DIA. 3 PLAGE DEC. 146" DIA. 1632" DIA. 3 PLAGE DEC. 148" DIA. 1656" DIA. 3 PLAGE DEC. 150" DIA. 1680" DIA. 3 PLAGE DEC. 152" DIA. 1704" DIA. 3 PLAGE DEC. 154" DIA. 1728" DIA. 3 PLAGE DEC. 156" DIA. 1752" DIA. 3 PLAGE DEC. 158" DIA. 1776" DIA. 3 PLAGE DEC. 160" DIA. 1800" DIA. 3 PLAGE DEC. 162" DIA. 1824" DIA. 3 PLAGE DEC. 164" DIA. 1848" DIA. 3 PLAGE DEC. 166" DIA. 1872" DIA. 3 PLAGE DEC. 168" DIA. 1896" DIA. 3 PLAGE DEC. 170" DIA. 1920" DIA. 3 PLAGE DEC. 172" DIA. 1944" DIA. 3 PLAGE DEC. 174" DIA. 1968" DIA. 3 PLAGE DEC. 176" DIA. 1992" DIA. 3 PLAGE DEC. 178" DIA. 2016" DIA. 3 PLAGE DEC. 180" DIA. 2040" DIA. 3 PLAGE DEC. 182" DIA. 2064" DIA. 3 PLAGE DEC. 184" DIA. 2088" DIA. 3 PLAGE DEC. 186" DIA. 2112" DIA. 3 PLAGE DEC. 188" DIA. 2136" DIA. 3 PLAGE DEC. 190" DIA. 2160" DIA. 3 PLAGE DEC. 192" DIA. 2184" DIA. 3 PLAGE DEC. 194" DIA. 2208" DIA. 3 PLAGE DEC. 196" DIA. 2232" DIA. 3 PLAGE DEC. 198" DIA. 2256" DIA. 3 PLAGE DEC. 200" DIA. 2280" DIA. 3 PLAGE DEC. 202" DIA. 2304" DIA. 3 PLAGE DEC. 204" DIA. 2328" DIA. 3 PLAGE DEC. 206" DIA. 2352" DIA. 3 PLAGE DEC. 208" DIA. 2376" DIA. 3 PLAGE DEC. 210" DIA. 2400" DIA. 3 PLAGE DEC. 212" DIA. 2424" DIA. 3 PLAGE DEC. 214" DIA. 2448" DIA. 3 PLAGE DEC. 216" DIA. 2472" DIA. 3 PLAGE DEC. 218" DIA. 2496" DIA. 3 PLAGE DEC. 220" DIA. 2520" DIA. 3 PLAGE DEC. 222" DIA. 2544" DIA. 3 PLAGE DEC. 224" DIA. 2568" DIA. 3 PLAGE DEC. 226" DIA. 2592" DIA. 3 PLAGE DEC. 228" DIA. 2616" DIA. 3 PLAGE DEC. 230" DIA. 2640" DIA. 3 PLAGE DEC. 232" DIA. 2664" DIA. 3 PLAGE DEC. 234" DIA. 2688" DIA. 3 PLAGE DEC. 236" DIA. 2712" DIA. 3 PLAGE DEC. 238" DIA. 2736" DIA. 3 PLAGE DEC. 240" DIA. 2760" DIA. 3 PLAGE DEC. 242" DIA. 2784" DIA. 3 PLAGE DEC. 244" DIA. 2808" DIA. 3 PLAGE DEC. 246" DIA. 2832" DIA. 3 PLAGE DEC. 248" DIA. 2856" DIA. 3 PLAGE DEC. 250" DIA. 2880" DIA. 3 PLAGE DEC. 252" DIA. 2904" DIA. 3 PLAGE DEC. 254" DIA. 2928" DIA. 3 PLAGE DEC. 256" DIA. 2952" DIA. 3 PLAGE DEC. 258" DIA. 2976" DIA. 3 PLAGE DEC. 260" DIA. 3000" DIA. 3 PLAGE DEC. 262" DIA. 3024" DIA. 3 PLAGE DEC. 264" DIA. 3048" DIA. 3 PLAGE DEC. 266" DIA. 3072" DIA. 3 PLAGE DEC. 268" DIA. 3096" DIA. 3 PLAGE DEC. 270" DIA. 3120" DIA. 3 PLAGE DEC. 272" DIA. 3144" DIA. 3 PLAGE DEC. 274" DIA. 3168" DIA. 3 PLAGE DEC. 276" DIA. 3192" DIA. 3 PLAGE DEC. 278" DIA. 3216" DIA. 3 PLAGE DEC. 280" DIA. 3240" DIA. 3 PLAGE DEC. 282" DIA. 3264" DIA. 3 PLAGE DEC. 284" DIA. 3288" DIA. 3 PLAGE DEC. 286" DIA. 3312" DIA. 3 PLAGE DEC. 288" DIA. 3336" DIA. 3 PLAGE DEC. 290" DIA. 3360" DIA. 3 PLAGE DEC. 292" DIA. 3384" DIA. 3 PLAGE DEC. 294" DIA. 3408" DIA. 3 PLAGE DEC. 296" DIA. 3432" DIA. 3 PLAGE DEC. 298" DIA. 3456" DIA. 3 PLAGE DEC. 300" DIA. 3480" DIA. 3 PLAGE DEC. 302" DIA. 3504" DIA. 3 PLAGE DEC. 304" DIA. 3528" DIA. 3 PLAGE DEC. 306" DIA. 3552" DIA. 3 PLAGE DEC. 308" DIA. 3576" DIA. 3 PLAGE DEC. 310" DIA. 3600" DIA. 3 PLAGE DEC. 312" DIA. 3624" DIA. 3 PLAGE DEC. 314" DIA. 3648" DIA. 3 PLAGE DEC. 316" DIA. 3672" DIA. 3 PLAGE DEC. 318" DIA. 3696" DIA. 3 PLAGE DEC. 320" DIA. 3720" DIA. 3 PLAGE DEC. 322" DIA. 3744" DIA. 3 PLAGE DEC. 324" DIA. 3768" DIA. 3 PLAGE DEC. 326" DIA. 3792" DIA. 3 PLAGE DEC. 328" DIA. 3816" DIA. 3 PLAGE DEC. 330" DIA. 3840" DIA. 3 PLAGE DEC. 332" DIA. 3864" DIA. 3 PLAGE DEC. 334" DIA. 3888" DIA. 3 PLAGE DEC. 336" DIA. 3912" DIA. 3 PLAGE DEC. 338" DIA. 3936" DIA. 3 PLAGE DEC. 340" DIA. 3960" DIA. 3 PLAGE DEC. 342" DIA. 3984" DIA. 3 PLAGE DEC. 344" DIA. 4008" DIA. 3 PLAGE DEC. 346" DIA. 4032" DIA. 3 PLAGE DEC. 348" DIA. 4056" DIA. 3 PLAGE DEC. 350" DIA. 4080" DIA. 3 PLAGE DEC. 352" DIA. 4104" DIA. 3 PLAGE DEC. 354" DIA. 4128" DIA. 3 PLAGE DEC. 356" DIA. 4152" DIA. 3 PLAGE DEC. 358" DIA. 4176" DIA. 3 PLAGE DEC. 360" DIA. 4200" DIA. 3 PLAGE DEC. 362" DIA. 4224" DIA. 3 PLAGE DEC. 364" DIA. 4248" DIA. 3 PLAGE DEC. 366" DIA. 4272" DIA. 3 PLAGE DEC. 368" DIA. 4296" DIA. 3 PLAGE DEC. 370" DIA. 4320" DIA. 3 PLAGE DEC. 372" DIA. 4344" DIA. 3 PLAGE DEC. 374" DIA. 4368" DIA. 3 PLAGE DEC. 376" DIA. 4392" DIA. 3 PLAGE DEC. 378" DIA. 4416" DIA. 3 PLAGE DEC. 380" DIA. 4440" DIA. 3 PLAGE DEC. 382" DIA. 4464" DIA. 3 PLAGE DEC. 384" DIA. 4488" DIA. 3 PLAGE DEC. 386" DIA. 4512" DIA. 3 PLAGE DEC. 388" DIA. 4536" DIA. 3 PLAGE DEC. 390" DIA. 4560" DIA. 3 PLAGE DEC. 392" DIA. 4584" DIA. 3 PLAGE DEC. 394" DIA. 4608" DIA. 3 PLAGE DEC. 396" DIA. 4632" DIA. 3 PLAGE DEC. 398" DIA. 4656" DIA. 3 PLAGE DEC. 400" DIA. 4680" DIA. 3 PLAGE DEC. 402" DIA. 4704" DIA. 3 PLAGE DEC. 404" DIA. 4728" DIA. 3 PLAGE DEC. 406" DIA. 4752" DIA. 3 PLAGE DEC. 408" DIA. 4776" DIA. 3 PLAGE DEC. 410" DIA. 4800" DIA. 3 PLAGE DEC. 412" DIA. 4824" DIA. 3 PLAGE DEC. 414" DIA. 4848" DIA. 3 PLAGE DEC. 416" DIA. 4872" DIA. 3 PLAGE DEC. 418" DIA. 4896" DIA. 3 PLAGE DEC. 420" DIA. 4920" DIA. 3 PLAGE DEC. 422" DIA. 4944" DIA. 3 PLAGE DEC. 424" DIA. 4968" DIA. 3 PLAGE DEC. 426" DIA. 4992" DIA. 3 PLAGE DEC. 428" DIA. 5016" DIA. 3 PLAGE DEC. 430" DIA. 5040" DIA. 3 PLAGE DEC. 432" DIA. 5064" DIA. 3 PLAGE DEC. 434" DIA. 5088" DIA. 3 PLAGE DEC. 436" DIA. 5112" DIA. 3 PLAGE DEC. 438" DIA. 5136" DIA. 3 PLAGE DEC. 440" DIA. 5160" DIA. 3 PLAGE DEC. 442" DIA. 5184" DIA. 3 PLAGE DEC. 444" DIA. 5208" DIA. 3 PLAGE DEC. 446" DIA. 5232" DIA. 3 PLAGE DEC. 448" DIA. 5256" DIA. 3 PLAGE DEC. 450" DIA. 5280" DIA. 3 PLAGE DEC. 452" DIA. 5304" DIA. 3 PLAGE DEC. 454" DIA. 5328" DIA. 3 PLAGE DEC. 456" DIA. 5352" DIA. 3 PLAGE DEC. 458" DIA. 5376" DIA. 3 PLAGE DEC. 460" DIA. 5400" DIA. 3 PLAGE DEC. 462" DIA. 5424" DIA. 3 PLAGE DEC. 464" DIA. 5448" DIA. 3 PLAGE DEC. 466" DIA. 5472" DIA. 3 PLAGE DEC. 468" DIA. 5496" DIA. 3 PLAGE DEC. 470" DIA. 5520" DIA. 3 PLAGE DEC. 472" DIA. 5544" DIA. 3 PLAGE DEC. 474" DIA. 5568" DIA. 3 PLAGE DEC. 476" DIA. 5592" DIA. 3 PLAGE DEC. 478" DIA. 5616" DIA. 3 PLAGE DEC. 480" DIA. 5640" DIA. 3 PLAGE DEC. 482" DIA. 5664" DIA. 3 PLAGE DEC. 484" DIA. 5688" DIA. 3 PLAGE DEC. 486" DIA. 5712" DIA. 3 PLAGE DEC. 488" DIA. 5736" DIA. 3 PLAGE DEC. 490" DIA. 5760" DIA. 3 PLAGE DEC. 492" DIA. 5784" DIA. 3 PLAGE DEC. 494" DIA. 5808" DIA. 3 PLAGE DEC. 496" DIA. 5832" DIA. 3 PLAGE DEC. 498" DIA. 5856" DIA. 3 PLAGE DEC. 500" DIA. 5880" DIA. 3 PLAGE DEC. 502" DIA. 5904" DIA. 3 PLAGE DEC. 504" DIA. 5928" DIA. 3 PLAGE DEC. 506" DIA. 5952" DIA. 3 PLAGE DEC. 508" DIA. 5976" DIA. 3 PLAGE DEC. 510" DIA. 6000" DIA. 3 PLAGE DEC. 512" DIA. 6024" DIA. 3 PLAGE DEC. 514" DIA. 6048" DIA. 3 PLAGE DEC. 516" DIA. 6072" DIA. 3 PLAGE DEC. 518" DIA. 6096" DIA. 3 PLAGE DEC. 520" DIA. 6120" DIA. 3 PLAGE DEC. 522" DIA. 6144" DIA. 3 PLAGE DEC. 524" DIA. 6168" DIA. 3 PLAGE DEC. 526" DIA. 6192" DIA. 3 PLAGE DEC. 528" DIA. 6216" DIA. 3 PLAGE DEC. 530" DIA. 6240" DIA. 3 PLAGE DEC. 532" DIA. 6264" DIA. 3 PLAGE DEC. 534" DIA. 6288" DIA. 3 PLAGE DEC. 536" DIA. 6312" DIA. 3 PLAGE DEC. 538" DIA. 6336" DIA. 3 PLAGE DEC. 540" DIA. 6360" DIA. 3 PLAGE DEC. 542" DIA. 6384" DIA. 3 PLAGE DEC. 544" DIA. 6408" DIA. 3 PLAGE DEC. 546" DIA. 6432" DIA. 3 PLAGE DEC. 548" DIA. 6456" DIA. 3 PLAGE DEC. 550" DIA. 6480" DIA. 3 PLAGE DEC. 552" DIA. 6504" DIA. 3 PLAGE DEC. 554" DIA. 6528" DIA. 3 PLAGE DEC. 556" DIA. 6552" DIA. 3 PLAGE DEC. 558" DIA. 6576" DIA. 3 PLAGE DEC. 560" DIA. 6600" DIA. 3 PLAGE DEC. 562" DIA. 6624" DIA. 3 PLAGE DEC. 564" DIA. 6648" DIA. 3 PLAGE DEC. 566" DIA. 6672" DIA. 3 PLAGE DEC. 568" DIA. 6696" DIA. 3 PLAGE DEC. 570" DIA. 6720" DIA. 3 PLAGE DEC. 572" DIA. 6744" DIA. 3 PLAGE DEC. 574" DIA. 6768" DIA. 3 PLAGE DEC. 576" DIA. 6792" DIA. 3 PLAGE DEC. 578" DIA. 6816" DIA. 3 PLAGE DEC. 580" DIA. 6840" DIA. 3 PLAGE DEC. 582" DIA. 6864" DIA. 3 PLAGE DEC. 584" DIA. 6888" DIA. 3 PLAGE DEC. 586" DIA. 6912" DIA. 3 PLAGE DEC. 588" DIA. 6936" DIA. 3 PLAGE DEC. 590" DIA. 6960" DIA. 3 PLAGE DEC. 592" DIA. 6984" DIA. 3 PLAGE DEC. 594" DIA. 7008" DIA. 3 PLAGE DEC. 596" DIA. 7032" DIA. 3 PLAGE DEC. 598" DIA. 7056" DIA. 3 PLAGE DEC. 600" DIA. 7080" DIA. 3 PLAGE DEC. 602" DIA. 7104" DIA. 3 PLAGE DEC. 604" DIA. 7128" DIA. 3 PLAGE DEC. 606" DIA. 7152" DIA. 3 PLAGE DEC. 608" DIA. 7176" DIA. 3 PLAGE DEC. 610" DIA. 7200" DIA. 3 PLAGE DEC. 612" DIA. 7224" DIA. 3 PLAGE DEC. 614" DIA. 7248" DIA. 3 PLAGE DEC. 616" DIA. 7272" DIA. 3 PLAGE DEC. 618" DIA. 7296" DIA. 3 PLAGE DEC. 620" DIA. 7320" DIA. 3 PLAGE DEC. 622" DIA. 7344" DIA. 3 PLAGE DEC. 624" DIA. 7368" DIA. 3 PLAGE DEC. 626" DIA. 7392" DIA. 3 PLAGE DEC. 628" DIA. 7416" DIA. 3 PLAGE DEC. 630" DIA. 7440" DIA. 3 PLAGE DEC. 632" DIA. 7464" DIA. 3 PLAGE DEC. 634" DIA. 7488" DIA. 3 PLAGE DEC. 636" DIA. 7512" DIA. 3 PLAGE DEC. 638" DIA. 7536" DIA. 3 PLAGE DEC. 640" DIA. 7560" DIA. 3 PLAGE DEC. 642" DIA. 7584" DIA. 3 PLAGE DEC. 644" DIA. 7608" DIA. 3 PLAGE DEC. 646" DIA. 7632" DIA. 3 PLAGE DEC. 648" DIA. 7656" DIA. 3 PLAGE DEC. 650" DIA. 7680" DIA. 3 PLAGE DEC. 652" DIA. 7704" DIA. 3 PLAGE DEC. 654" DIA. 7728" DIA. 3 PLAGE DEC. 656" DIA. 7752" DIA. 3 PLAGE DEC. 658" DIA. 7776" DIA. 3 PLAGE DEC. 660" DIA. 7800" DIA. 3 PLAGE DEC. 662" DIA. 7824" DIA. 3 PLAGE DEC. 664" DIA. 7848" DIA. 3 PLAGE DEC. 666" DIA. 7872" DIA. 3 PLAGE DEC. 668" DIA. 7896" DIA. 3 PLAGE DEC. 670" DIA. 7920" DIA. 3 PLAGE DEC. 672" DIA. 7944" DIA. 3 PLAGE DEC. 674" DIA. 7968" DIA. 3 PLAGE DEC. 676" DIA. 7992" DIA. 3 PLAGE DEC. 678" DIA. 8016" DIA. 3 PLAGE DEC. 680" DIA. 8040" DIA. 3 PLAGE DEC. 682" DIA. 8064" DIA. 3 PLAGE DEC. 684" DIA. 8088" DIA. 3 PLAGE DEC. 686" DIA. 8112" DIA. 3 PLAGE DEC. 688" DIA. 8136" DIA. 3 PLAGE DEC. 690" DIA. 8160" DIA. 3 PLAGE DEC. 692" DIA. 8184" DIA. 3 PLAGE DEC. 694" DIA. 8208" DIA. 3 PLAGE DEC. 696" DIA. 8232" DIA. 3 PLAGE DEC. 698" DIA. 8256" DIA. 3 PLAGE DEC. 700" DIA. 8280" DIA. 3 PLAGE DEC. 702" DIA. 8304" DIA. 3 PLAGE DEC. 704" DIA. 8328" DIA. 3 PLAGE DEC. 706" DIA. 8352" DIA. 3 PLAGE DEC. 708" DIA. 8376" DIA. 3 PLAGE DEC. 710" DIA. 8400" DIA. 3 PLAGE DEC. 712" DIA. 8424" DIA. 3 PLAGE DEC. 714" DIA. 8448" DIA. 3 PLAGE DEC. 716" DIA. 8472" DIA. 3 PLAGE DEC. 718" DIA. 8496" DIA. 3 PLAGE DEC. 720" DIA. 8520" DIA. 3 PLAGE DEC. 722" DIA. 8544" DIA. 3 PLAGE DEC. 724" DIA. 8568" DIA. 3 PLAGE DEC. 726" DIA. 8592" DIA. 3 PLAGE DEC. 728" DIA. 8616" DIA. 3 PLAGE DEC. 730" DIA. 8640" DIA. 3 PLAGE DEC. 732" DIA. 8664" DIA. 3 PLAGE DEC. 734" DIA. 8688" DIA. 3 PLAGE DEC. 736" DIA. 8712" DIA. 3 PLAGE DEC. 738" DIA. 8736" DIA. 3 PLAGE DEC. 740" DIA. 8760" DIA. 3 PLAGE DEC. 742" DIA. 8784" DIA. 3 PLAGE DEC. 744" DIA. 8808" DIA. 3 PLAGE DEC. 746" DIA. 8832" DIA. 3 PLAGE DEC. 748" DIA. 8856" DIA. 3 PLAGE DEC. 750" DIA. 8880" DIA. 3 PLAGE DEC. 752" DIA. 8904" DIA. 3 PLAGE DEC. 754" DIA. 8928" DIA. 3 PLAGE DEC. 756" DIA. 8952" DIA. 3 PLAGE DEC. 758" DIA. 8976" DIA. 3 PLAGE DEC. 760" DIA. 9000" DIA. 3 PLAGE DEC. 762" DIA. 9024" DIA. 3 PLAGE DEC. 764" DIA. 9048" DIA. 3 PLAGE DEC. 766" DIA. 9072" DIA. 3 PLAGE DEC. 768" DIA. 9096" DIA. 3 PLAGE DEC. 770" DIA. 9120" DIA. 3 PLAGE DEC. 772" DIA. 9144" DIA. 3 PLAGE DEC. 774" DIA. 9168" DIA. 3 PLAGE DEC. 776" DIA. 9192" DIA. 3 PLAGE DEC. 778" DIA. 9216" DIA. 3 PLAGE DEC. 780" DIA. 9240" DIA. 3 PLAGE DEC. 782" DIA. 9264" DIA. 3 PLAGE DEC. 784" DIA. 9288" DIA. 3 PLAGE DEC. 786" DIA. 9312" DIA. 3 PLAGE DEC. 788" DIA. 9336" DIA. 3 PLAGE DEC. 790" DIA. 9360" DIA. 3 PLAGE DEC. 792" DIA. 9384" DIA. 3 PLAGE DEC. 794" DIA. 9408" DIA. 3 PLAGE DEC. 796" DIA. 9432" DIA. 3 PLAGE DEC. 798" DIA. 9456" DIA. 3 PLAGE DEC. 800" DIA. 9480" DIA. 3 PLAGE DEC. 802" DIA. 9504" DIA. 3 PLAGE DEC. 804" DIA. 9528" DIA. 3 PLAGE DEC. 806" DIA. 9552" DIA. 3 PLAGE DEC. 808" DIA. 9576" DIA. 3 PLAGE DEC. 810" DIA. 9600" DIA. 3 PLAGE DEC. 812" DIA. 9624" DIA. 3 PLAGE DEC. 814" DIA. 9648" DIA. 3 PLAGE DEC. 816" DIA. 9672" DIA. 3 PLAGE DEC. 818" DIA. 9696" DIA. 3 PLAGE DEC. 820" DIA. 9720" DIA. 3 PLAGE DEC. 822" DIA. 9744" DIA. 3 PLAGE DEC. 824" DIA. 9768" DIA. 3 PLAGE DEC. 826" DIA. 9792" DIA. 3 PLAGE DEC. 828" DIA. 9816" DIA. 3 PLAGE DEC. 830" DIA. 9840" DIA. 3 PLAGE DEC. 832" DIA. 9864" DIA. 3 PLAGE DEC. 834" DIA. 9888" DIA. 3 PLAGE DEC. 836" DIA. 9912" DIA. 3 PLAGE DEC. 838" DIA. 9936" DIA. 3 PLAGE DEC. 840" DIA. 9960" DIA. 3 PLAGE DEC. 842" DIA. 9984" DIA. 3 PLAGE DEC. 844" DIA. 10008" DIA. 3 PLAGE DEC. 846" DIA. 10032" DIA. 3 PLAGE DEC. 848" DIA. 10056" DIA. 3 PLAGE DEC. 850" DIA. 10080" DIA. 3 PLAGE DEC. 852" DIA. 10104" DIA. 3 PLAGE DEC. 854" DIA. 10128" DIA. 3 PLAGE DEC. 856" DIA. | | | |

| REVISIONS | | | | | | |
|-----------|------|-----|-------------|------|----|-----|
| ECO | ZONE | REV | DESCRIPTION | DATE | BY | APP |
| | | | | | | |

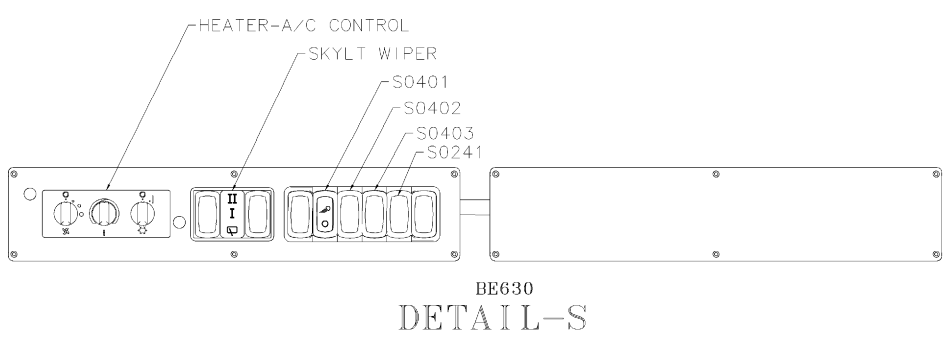
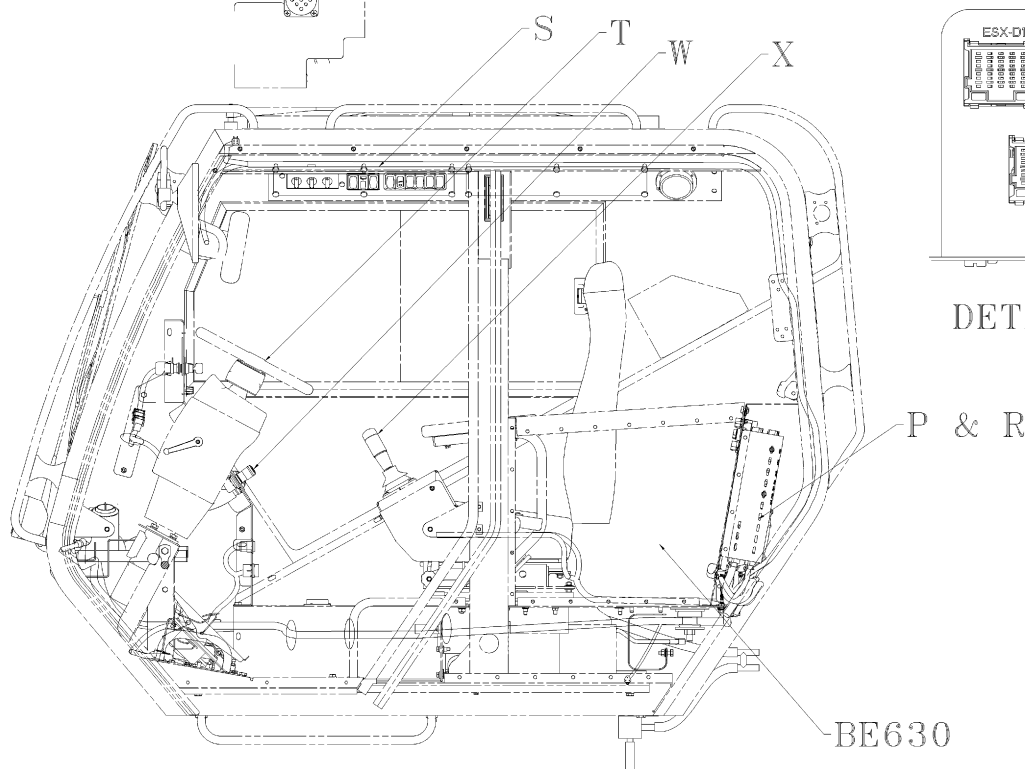
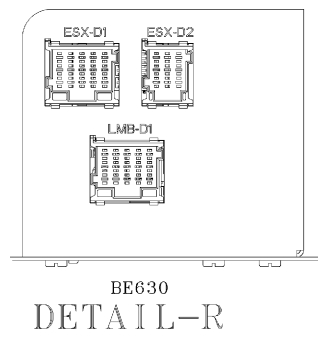
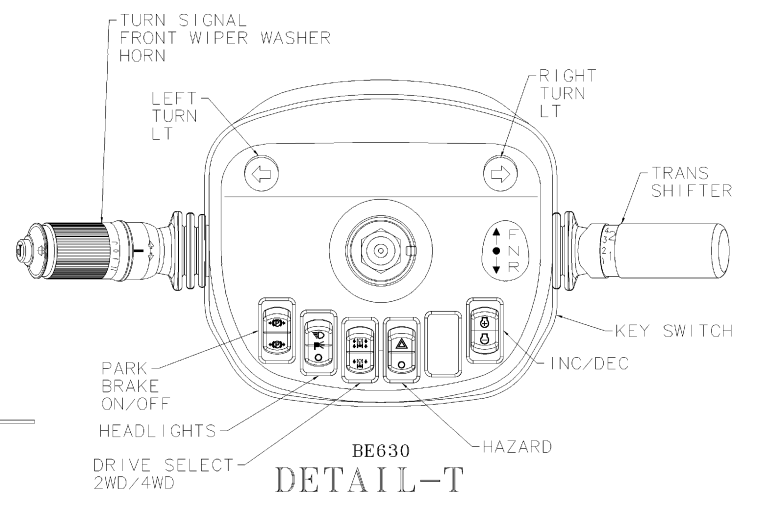
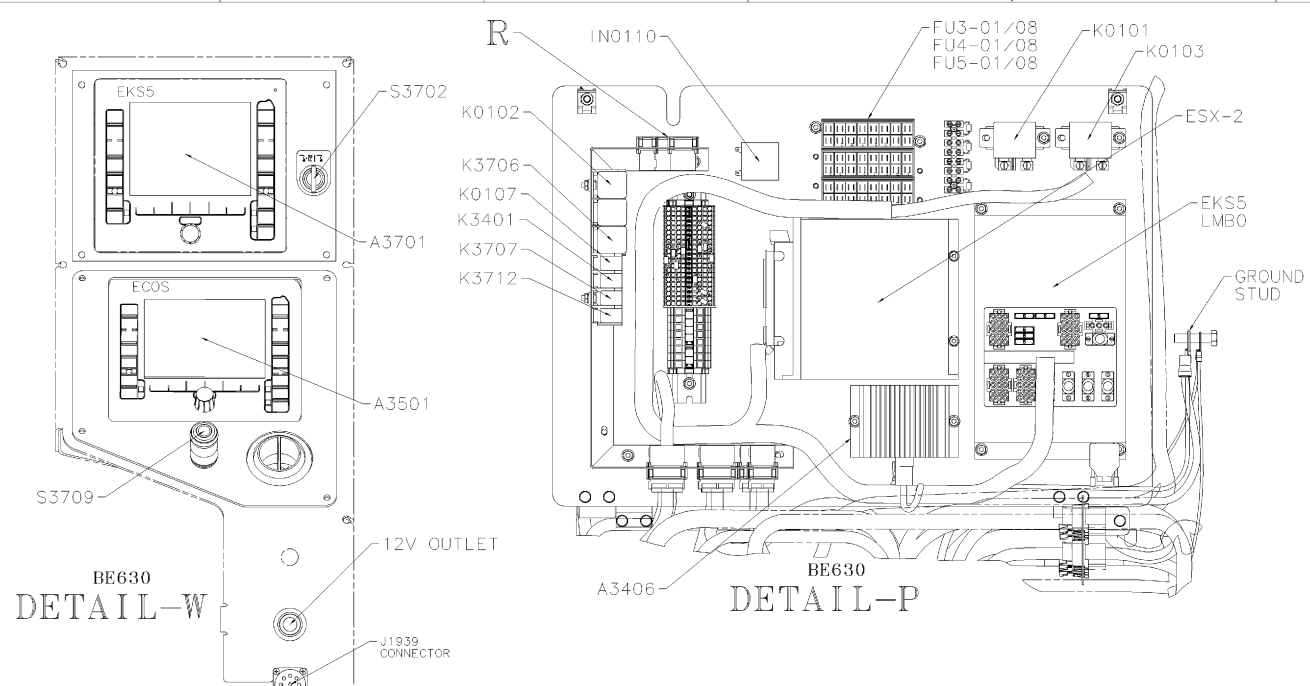

THIS DRAWING IS THE PROPERTY OF GROVE. IT IS TO BE USED ONLY FOR THE PROJECT AND SITE SPECIFICALLY IDENTIFIED HEREON. IT IS NOT TO BE REPRODUCED, COPIED, OR TRANSMITTED IN ANY FORM OR BY ANY MEANS, ELECTRONIC OR MECHANICAL, INCLUDING PHOTOCOPYING, RECORDING, OR BY ANY INFORMATION STORAGE AND RETRIEVAL SYSTEM. GROVE ASSUMES NO LIABILITY FOR DAMAGES OF ANY KIND, INCLUDING CONSEQUENTIAL DAMAGES, ARISING FROM THE USE OF THIS DRAWING. THE USER OF THIS DRAWING SHALL BE RESPONSIBLE FOR OBTAINING ALL NECESSARY PERMITS AND APPROVALS FROM THE APPROPRIATE AUTHORITIES. GROVE SHALL BE CONSIDERED AS ACCEPTOR OF THE FOREGOING CONDITIONS.

| | | | | | | |
|--|---|--|---|---|--|------------------------------|
| PRIVATE LABELING REQUIREMENT TO COMPANY, INC. SPECIFICATION REQUIREMENTS FOR COMPONENTS LISTED IN 80023078 | ADDITIONAL APPROVALS DATE 3RD ANGLE PROJECTION W/7 ELEC. SYM. IF IN DOUBT ASK, REMOVE ALL DIMS AND SHARP EDGES. | DATE TITLE SPEC. NUMBER RT9150E4 | USE DIM FOR ALTERNATES DO NOT SCALE DRAWING TO DIMENSIONS UNLESS OTHERWISE SPECIFIED IN DIM. ECC. PLACES IN DIM. UNLESS OTHERWISE SPECIFIED IN DIM. UNLESS OTHERWISE SPECIFIED IN DIM. UNLESS OTHERWISE SPECIFIED N/A TO MATERIAL THICKNESS | CONTRACT NO. 205230 APPROVALS DATE APPROVED DATE APPROVED DATE | GROVE ELECTRICAL SCHEMATIC RT9150E4 SHEET NUMBER 80023078 SCALE PERCENT 11 OF 13 | REV J DATE 12/31/11 |
|--|---|--|---|---|--|------------------------------|

80023078

12

A

| REVISIONS | | | | | | |
|-----------|------|-----|---|-----------|-----|-----|
| ECO | ZONE | REV | DESCRIPTION | DATE | BY | APP |
| 206003 | ALL | F | ADDED W/RE 2070, 1813, 1814, 1815, 1816 FOR OMS (OPT) | 19-JAN-11 | LAM | JRL |

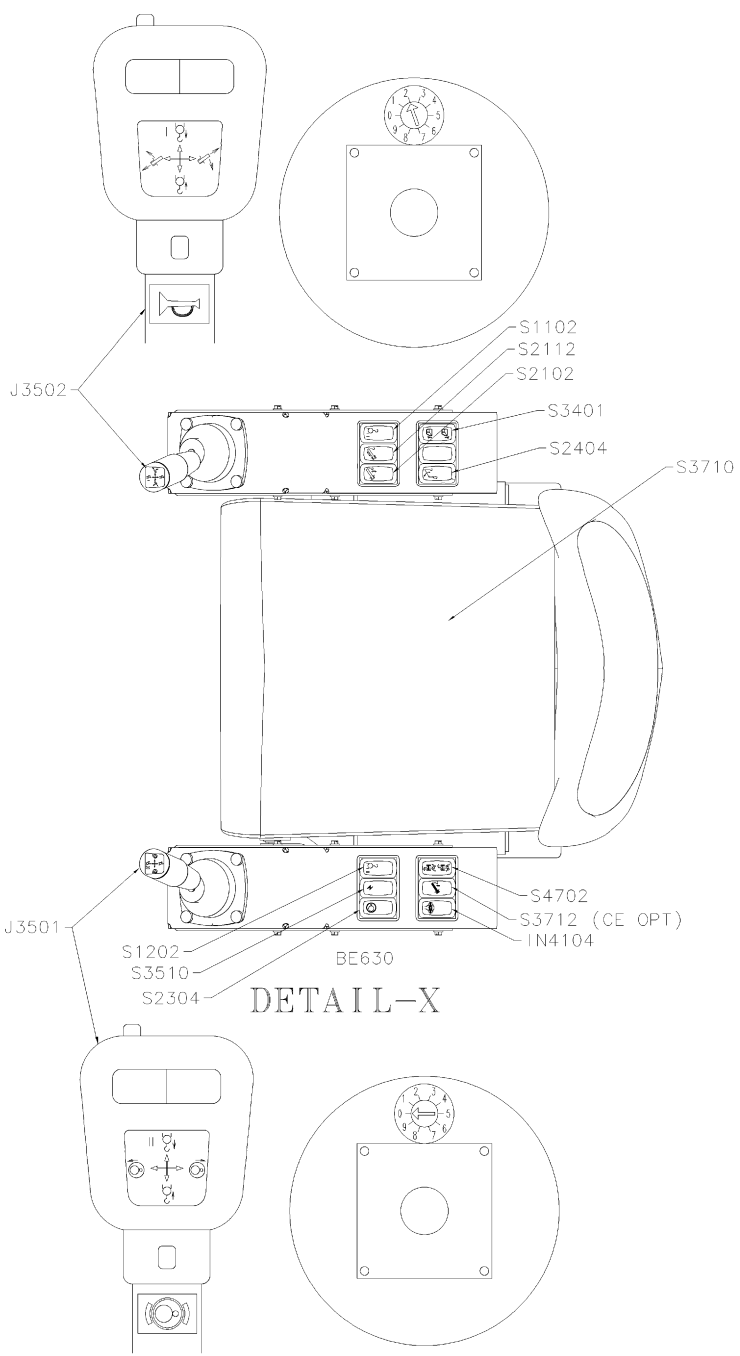

DETAIL-X

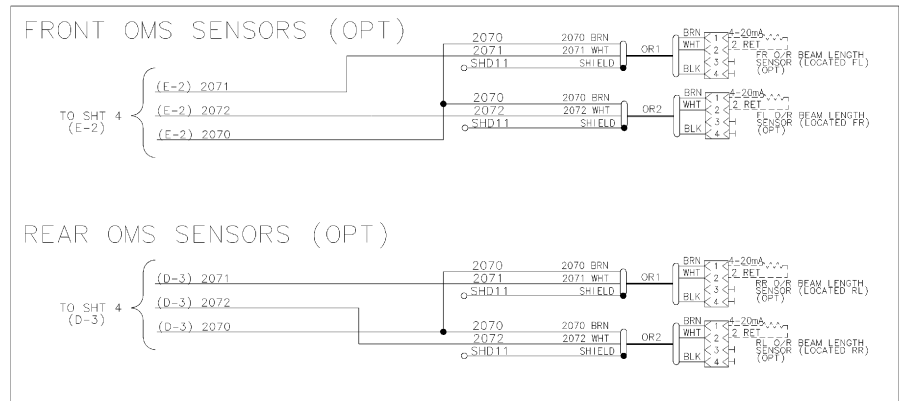

THESE DRAWINGS AND SPECIFICATIONS ARE THE PROPERTY OF GROVE. ANY REPRODUCTION OR TRANSMISSION OF THESE DRAWINGS OR SPECIFICATIONS IN ANY FORM OR BY ANY MEANS WITHOUT THE WRITTEN PERMISSION OF GROVE IS STRICTLY PROHIBITED. GROVE ASSUMES NO LIABILITY FOR DAMAGES OF ANY KIND ARISING FROM THE USE OF THESE DRAWINGS OR SPECIFICATIONS.

| | | | | | | | |
|---|---|----------------------------------|--|---|---|--|--|
| PRIVATE LABELING REQUIREMENT TO COMPANY LOGO SPECIFICATION REQUIREMENTS ENTERED IN 625500-05-030 | ADDITIONAL APPROVALS APPROVALS DATE | DATE 3RD ANGLE PROJECTION | W/FILE SPEC. NUMBER (SEE BOM FOR ALTERNATE) | DO NOT SCALE DRAWING IN DIM. OCC. PLACES MM DIM. N/A 4.06" ± PLACE DEC ±0.004 1.016" ± PLACE DEC ±0.004 ±2° ANGULAR DIM ±2° N/A TO MATERIAL THICKNESS | TO FRAMES UNLESS OTHERWISE SPECIFIED APPROVALS DATE APPROVED CAJIA | CONTRACT NO. 205230 DATE 12/31/11 | GROVE ELECTRICAL SCHEMATIC RT9150E4 REVISION DATE 8/20/2007B REV J |
|---|---|----------------------------------|--|---|---|--|--|